

# **Tank Car Industry – Research and Development**

**Bob Toms**

**Director – Research and Development**

**Union Tank Car Company**

**MARTS – Minneapolis, MN September 19, 2011**

- **Advanced Tank Car Collaborative Research Program**
- **NARS Response**
- **Tank Car Telematics**
- **Stub Sill Development**
- **End Platform Development**

# Tank Car Industry – Research and Development

## ATCCRP - Safety & Security





# Tank Car Industry – Research and Development ATCCRP - Safety & Security



Railroad operating environment provides an equipment testing laboratory to extremes.



Innovation efforts must remain focused on  
Safety, Security and Productivity.

# Tank Car Industry – Research and Development ATCCRP

- Prioritizing TWP for Project Funding, such as:
  - Evaluating & Testing Composites & Steels
  - Defining & Modeling Test Impact Scenarios
  - Defining Performance Based Test Standards
  - Conditional Probability of Release (CPR)
- DHS/TSA Performing Security Testing
- Similar ATCCRP solutions may be applied to Crude/Ethanol (Flammable) and in future to Environmentally Sensitive Materials



# Tank Car Industry – Research and Development ATCCRP – Continuation of NGRTC



# Tank Car Industry – Research and Development

## ATCCRP – Need for Modeling

Time = 0.52  
Contours of Effective Plastic Strain  
max ipL value  
min=0.000212409, at elem# 143490  
max=0.516112, at elem# 72229

Fringe Levels

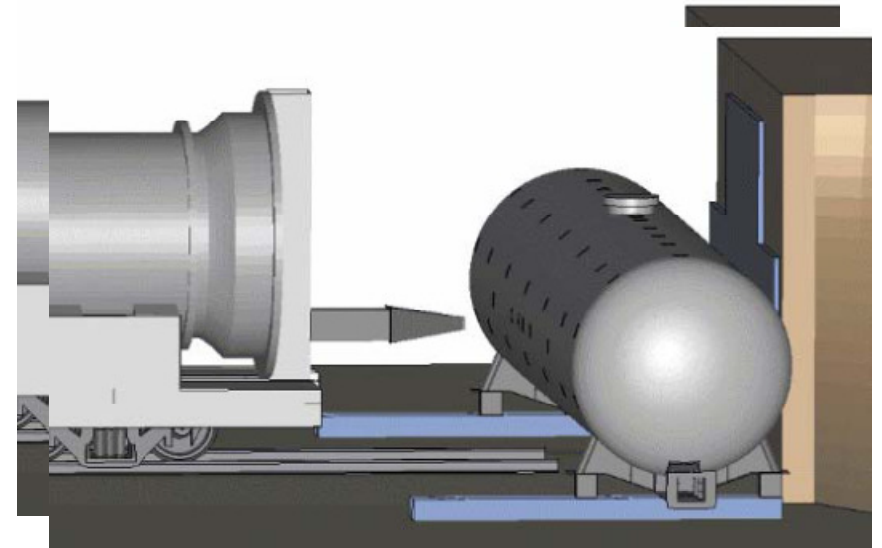
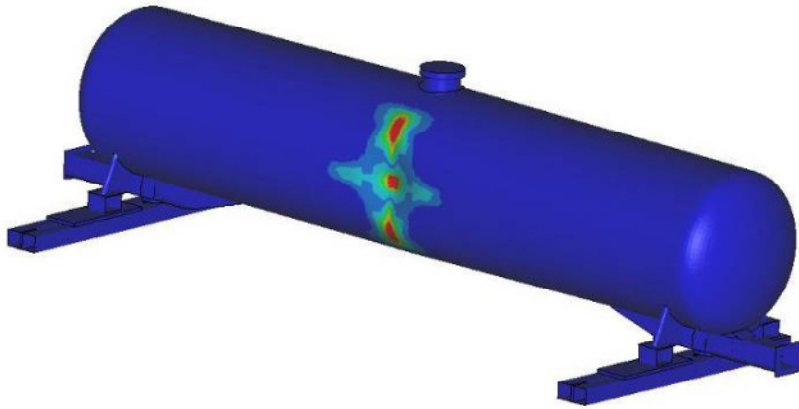
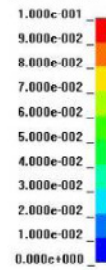

Time = 0

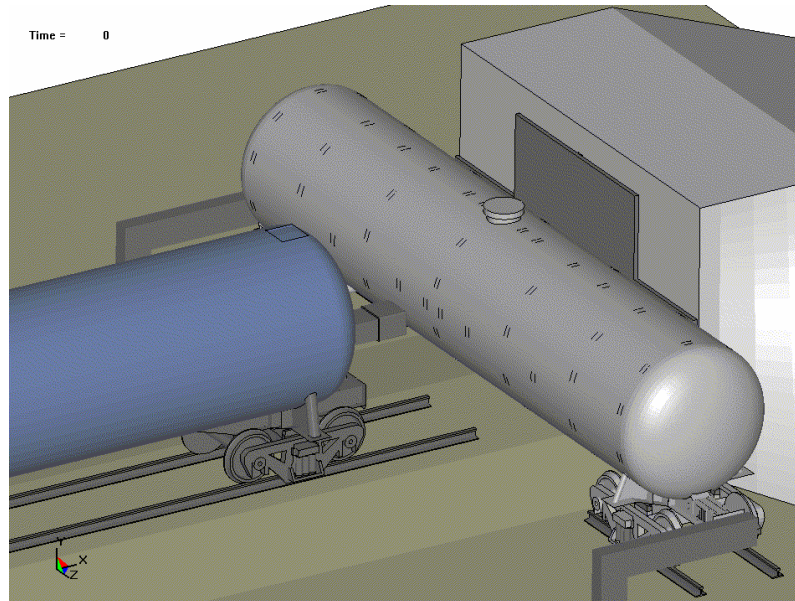

# Tank Car Industry – Research and Development ATCCRP - Safety & Security

- <E:\6 X 6 Impactor.avi>
- [E:\05-RC South Tower \(5 minutes\).wmv](E:\05-RC South Tower (5 minutes).wmv)
- [E:\03-RA South Tower \(5 minutes\).wmv](E:\03-RA South Tower (5 minutes).wmv)

# Tank Car Industry – Research and Development

## **NARS**

### Industry NARs Survey:

- 80% NARS from Manway
- 80% of Manway NAR from improper tightening/gasket sealing

### Results of NARs:

- Fines
- Loss revenue, i.e. : Shopping costs, late shipment, rejected commodity load
- Damage to Environment
- Safety



# Tank Car Industry – Research and Development New Manway Development

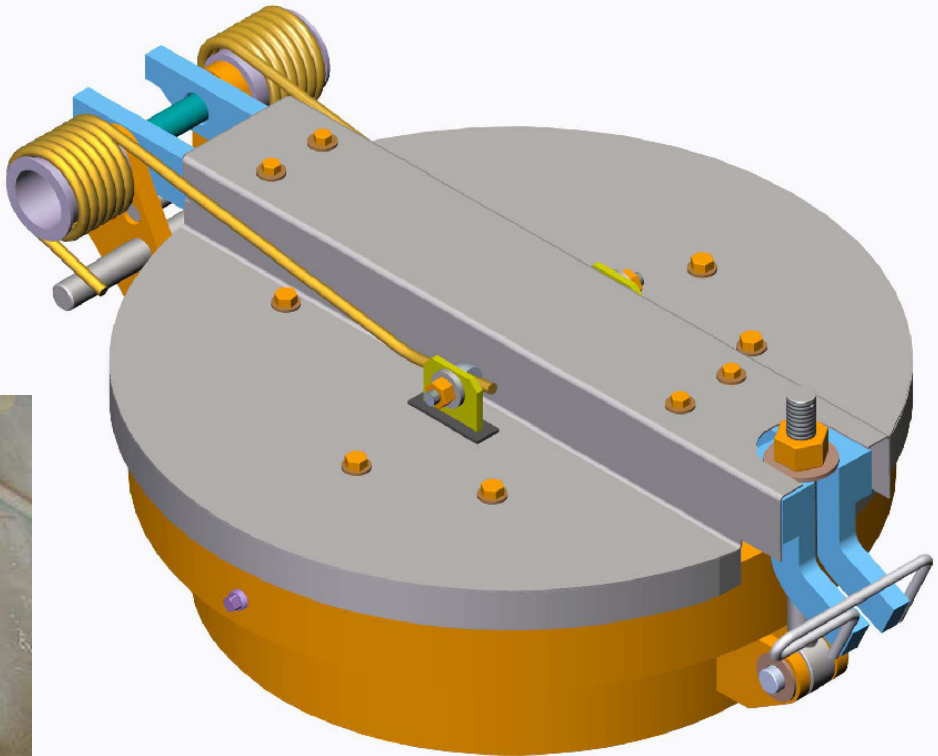

# Tank Car Industry – Research and Development DHS Security Grant

## DHS Update:

- \$15M in Grants
  - Preparedness
  - GPS
  - Training
- Several Builders Installing
- Several Shippers Installing
- Grant thru 2012



# Tank Car Industry – Research and Development





# Telematics

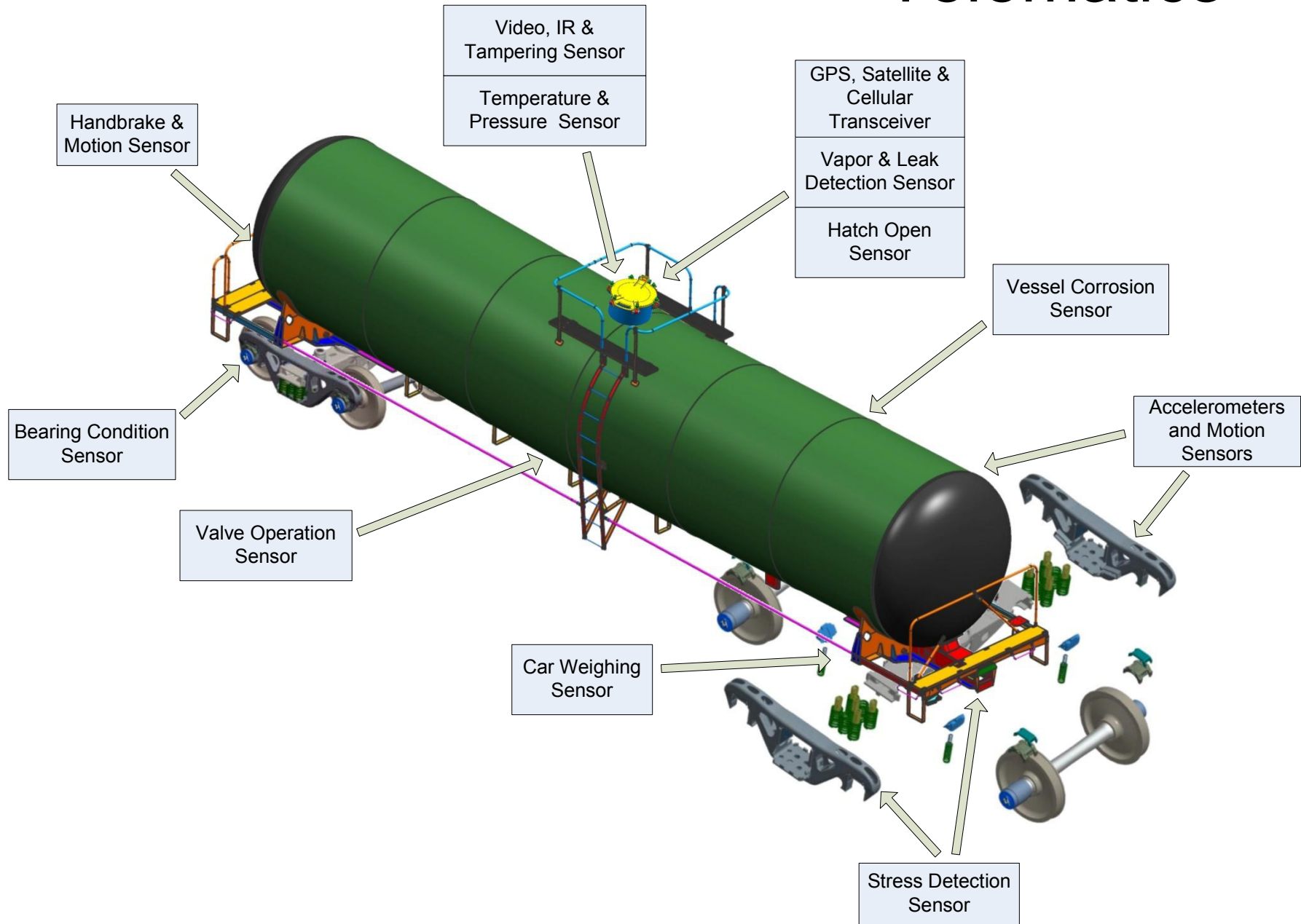

# Tank Car Industry – Research and Development Telematics



# Tank Car Industry – Research and Development Telematics





# Tank Car Industry – Research and Development

## 1 Million Mile Stub Sill based on recent REPOS Data Set

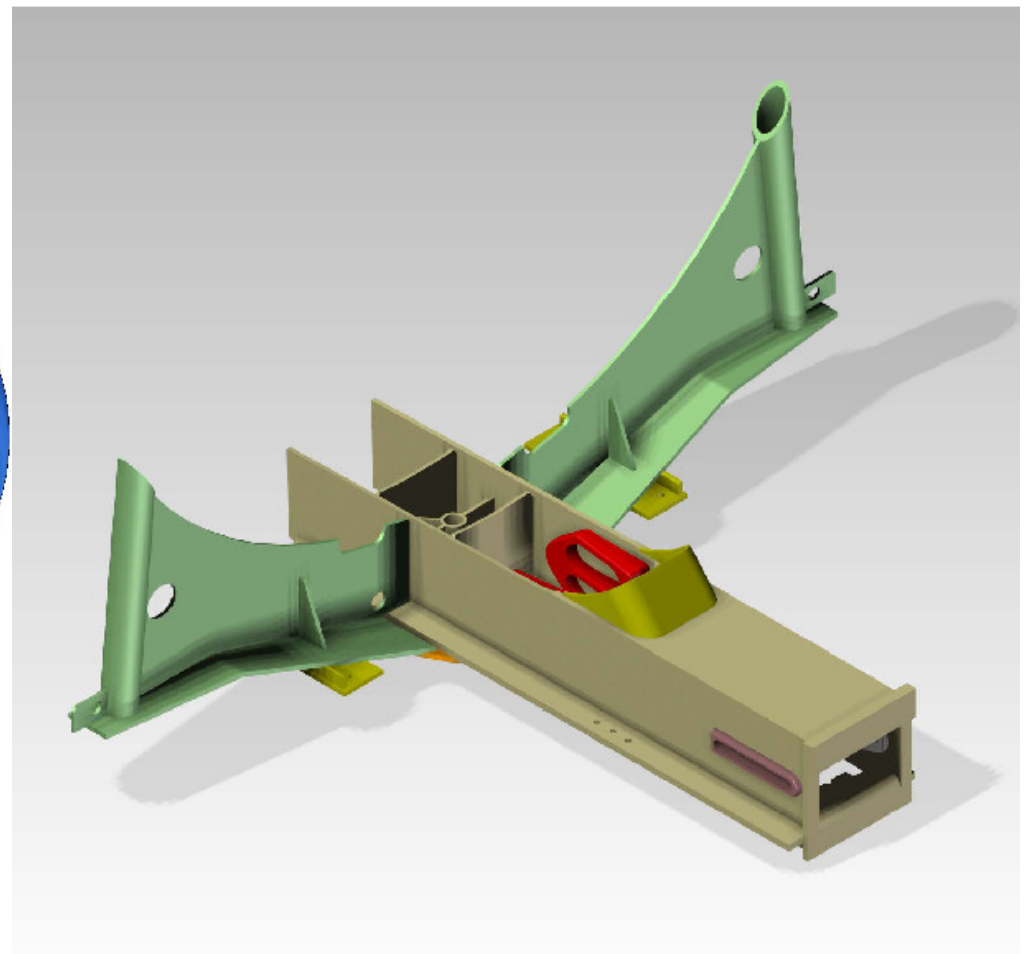
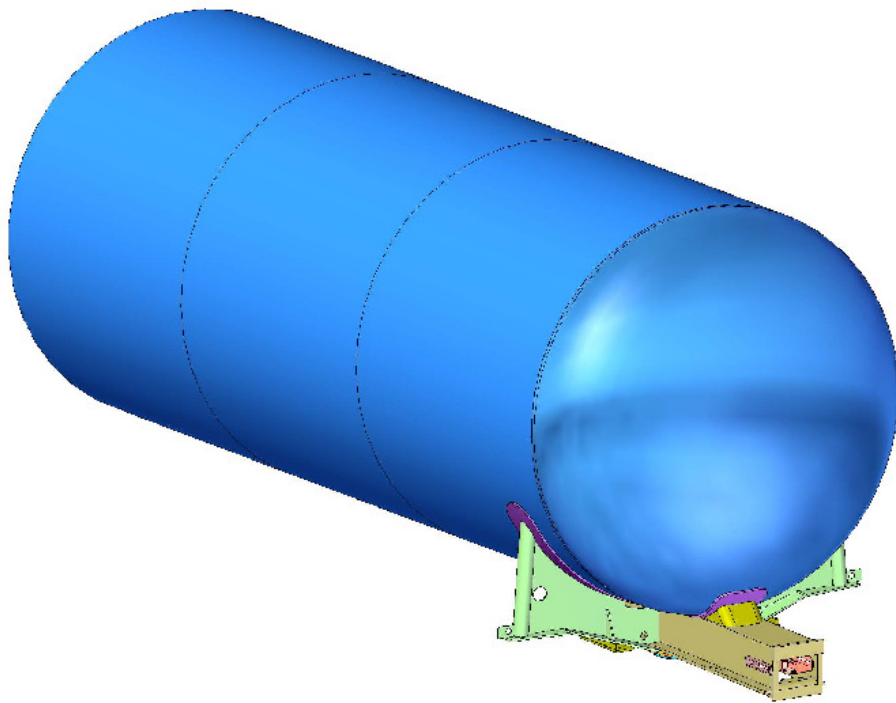

# Tank Car Industry – Research and Development End Platform – Safety Appliance

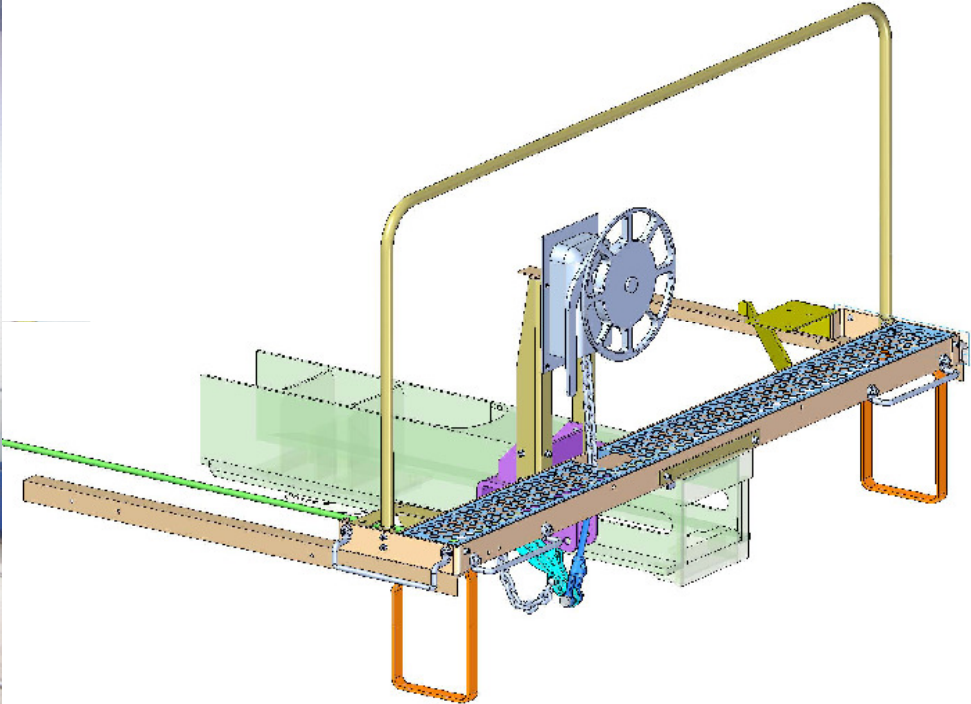

# Tank Car Industry – Research and Development End Platform – Safety Appliance

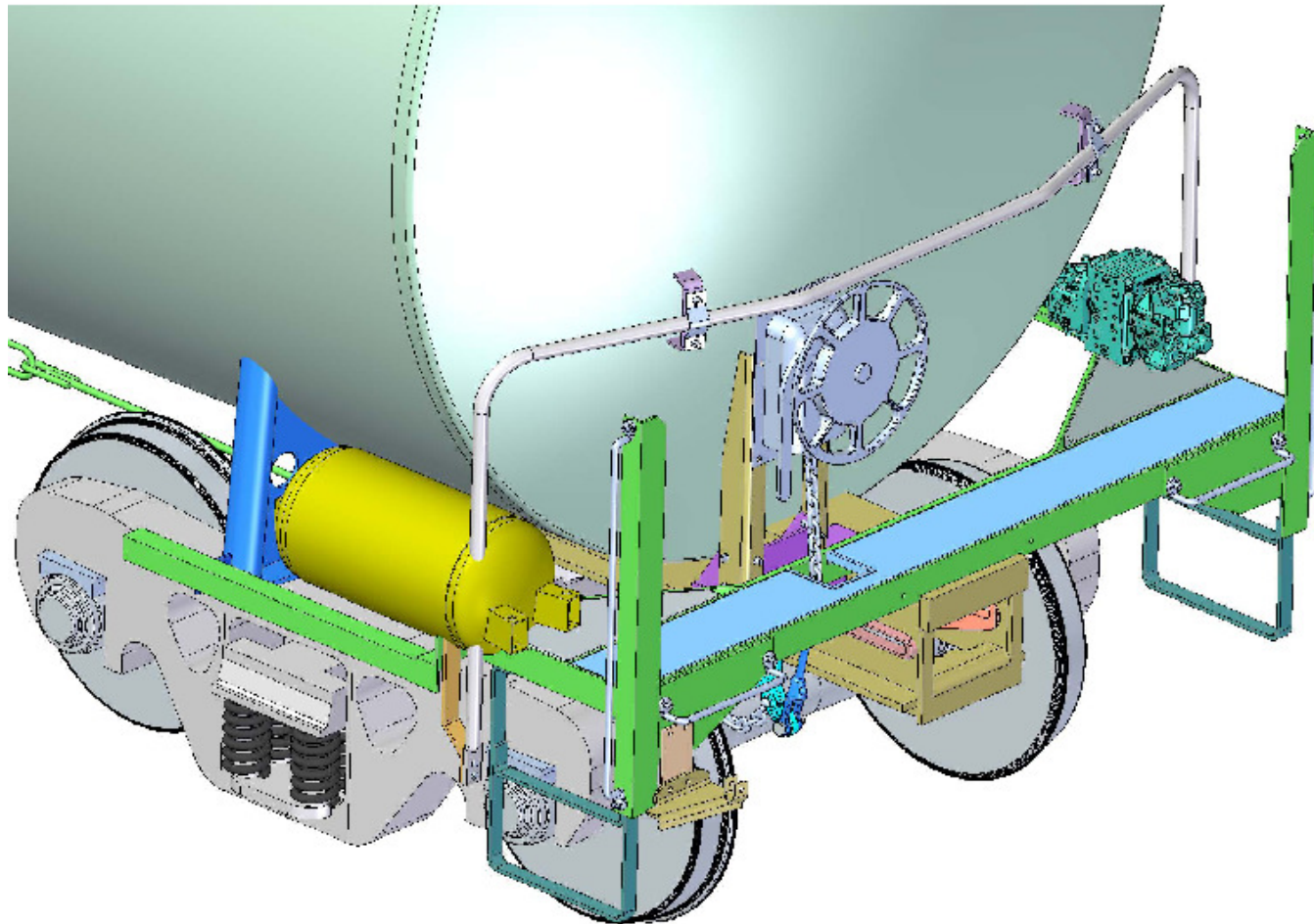



# Tank Car Industry – Research and Development End Platform – Safety Appliance

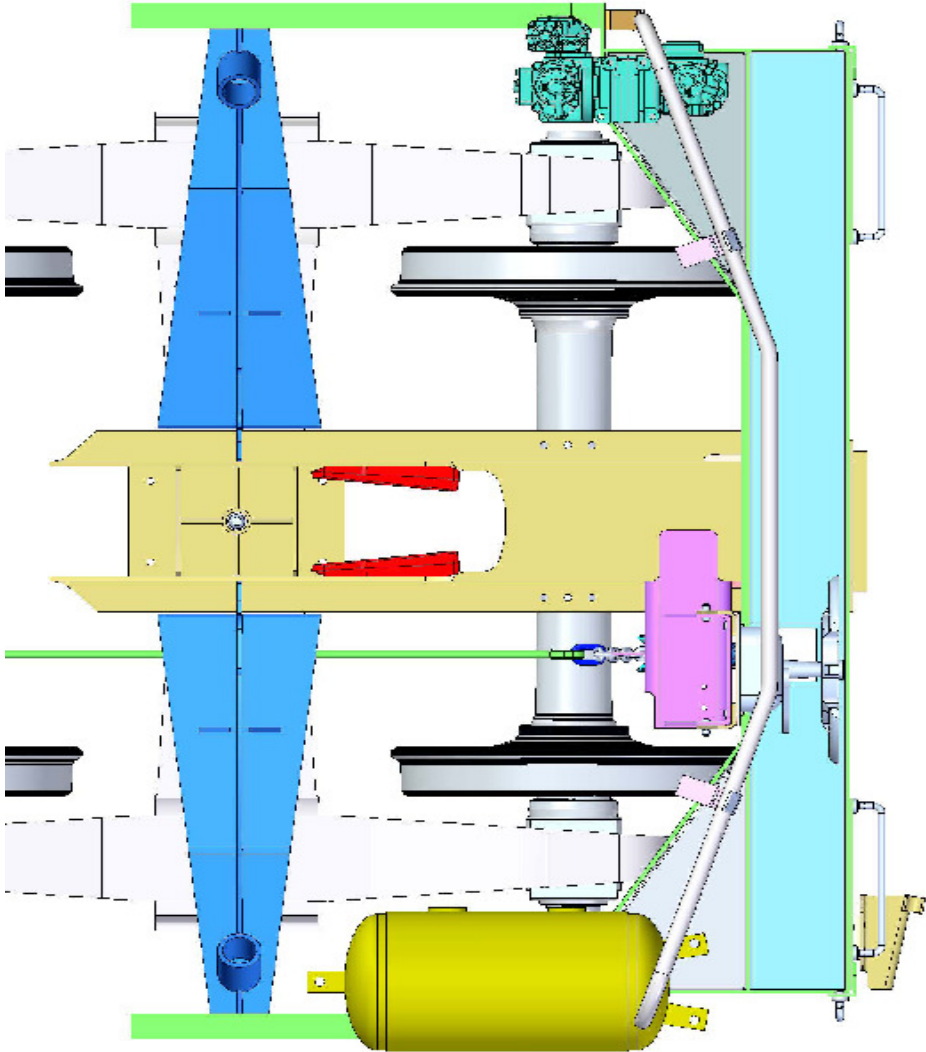

# Tank Car Industry – Research and Development

## End Platform – Safety Appliance

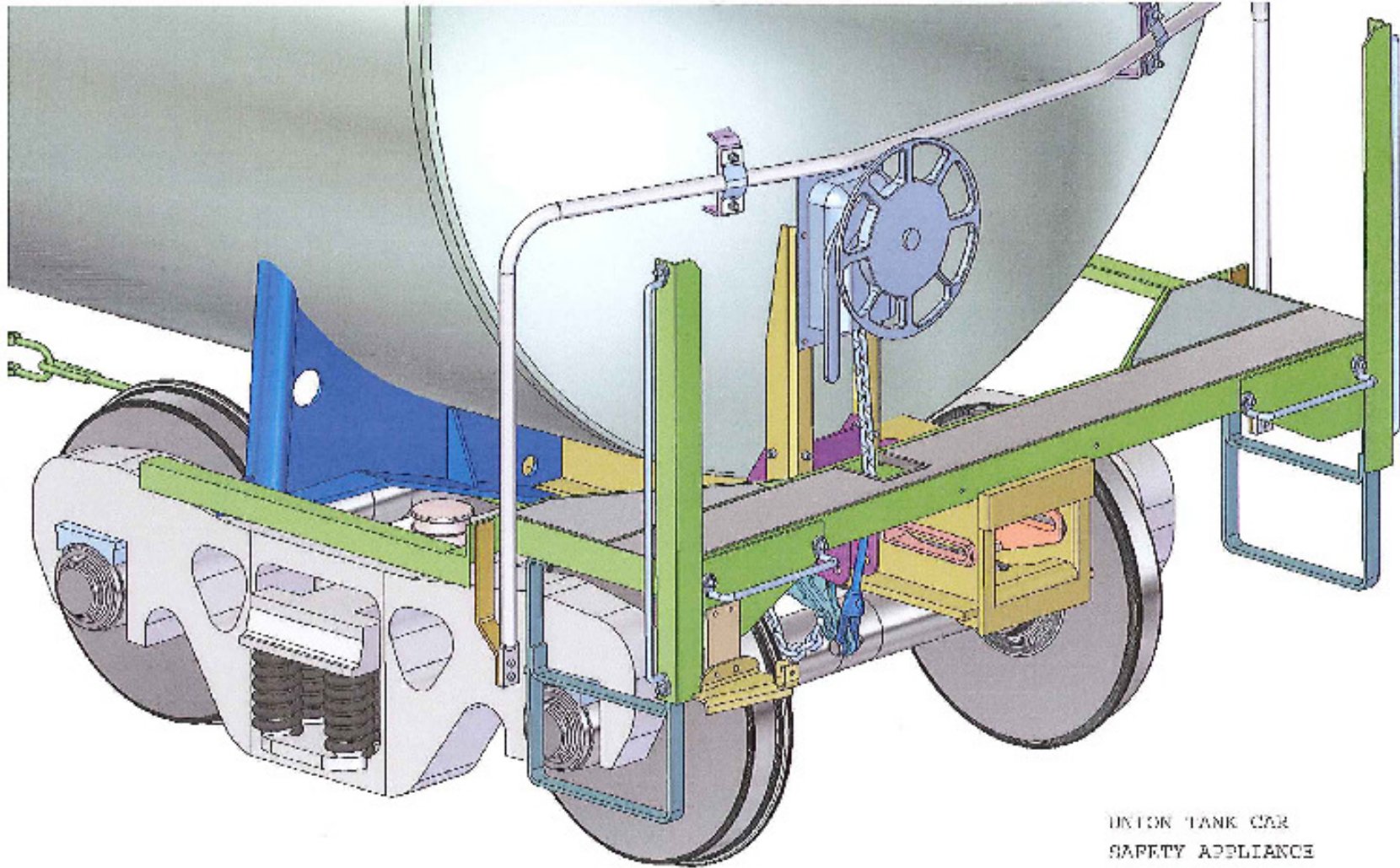

UNION TANK CAR  
SAFETY APPLIANCE  
END PLATFORM  
EXTENDED HANDRAIL/  
TO PLATFORM FRAME  
07/19/11 GCW  
UNION TANK CAR

Tank Car Industry – Research and Development

**Thank You**